

尼龙管 Nylon tube



CR-PA11 PA12  
PA6-001



CR-PA11 PA12  
PA6-002



CR-PA11 PA12  
PA6-003



CR-PA11 PA12  
PA6-004



CR-PA11 PA12  
PA6-005

O.D×W.T	O.D	I.D	Color	Price
16×2	16	12		
15×1.5	15	12		
14×2	14	10		
14×1.5	14	11		
12×2	12	8		
12×1.5	12	9		
12×1	12	10		
11×1.5	11	8		
10×1.5	10	7		
10×1.25	10	7.5		
10×1	10	8		

NOTE: Available Color: Black,Red,Yellow,Blue,White,Nature

Material: PA11 PA12 PA6

双层尼龙管  
Double Layer Nylon Tube & Reinforced Tube



O.D×W.T	Color	Price
1/4		
3/8		
12		
1/2		
5/8		
3/4		

NOTE: Available Color: Black,Red,Yellow,Blue,White,Nature Material: PA11 PA12



PU管 PU Hose



CR-PU-001

CR-PU-002

CR-PU-003

CR-PU-004

CR-PU-005

O.D×W.T	O.D	I.D	Color	Price
16×2	16	12		
14×2	14	10		
12×2	12	8		
12×1.5	12	9		
12×1	12	10		
10×1	10	8		
10×1.75	10	6.5		
8×1.5	8	5		

O.D×W.T	O.D	I.D	Color	Price
8×1.25	8	5.5		
8×1	8	6		
6×1	6	4		
5×1	5	3		
4×1	4	2		
4×0.75	4	2.5		
3×0.5	3	2		

螺旋管

Trailer Air Brake Hose/Air Brake Coil/Suzi Hose/Air Coil



CR-PA-001 PA12 12X9 M22X1.5 M16X1.5 1/2



CR-PA-002 PA12 12X9 M22X1.5 M16X1.5 1/2



CR-PA-003 PA12 12X9 M22X1.5 M16X1.5 1/2



CR-PA-004 PA12 12X9 M22X1.5 M16X1.5 1/2



CR-PA-005 PA12 12X9 M22X1.5 M16X1.5 1/2



CR-PA-006 PA12 12X9 M22X1.5 M16X1.5 1/2



CR-PA-007 PA12 12X9 M22X1.5 M16X1.5 1/2



CR-PA-008 PA12 12X9 M22X1.5 M16X1.5 1/2



CR-PA-009 PA12 12X9 M22X1.5 M16X1.5 1/2



CR-PA-010 PA12 12X9 M22X1.5 M16X1.5 1/2

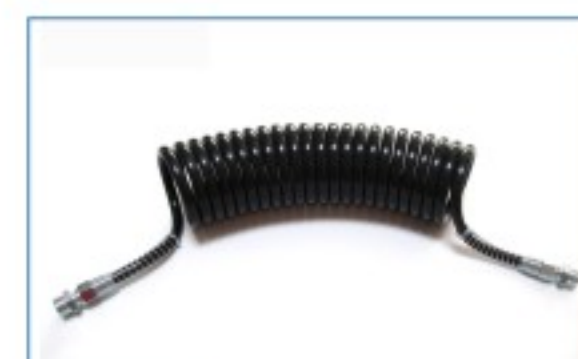

CR-PA-011 PA12 12X9 M22X1.5 M16X1.5 1/2



CR-PA-012 PA12 12X9 M22X1.5 M16X1.5 1/2



CR-PA-013 PA12 12X9 M22X1.5 M16X1.5 NPT1/2



CR-PA-014 PA12 12X9 M22X1.5 M16X1.5 NPT1/2

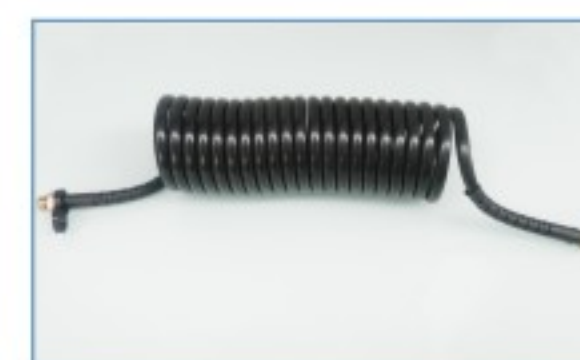

CR-PA-015 PA12 12X9 M22X1.5 M16X1.5 1/2

NOTE: Available Color: Black,Red,Yellow,Blue Material: PA11 PA12 PA6



螺旋管

Trailer Air Brake Hose/Air Brake Coil/Suzi Hose/Air Coil

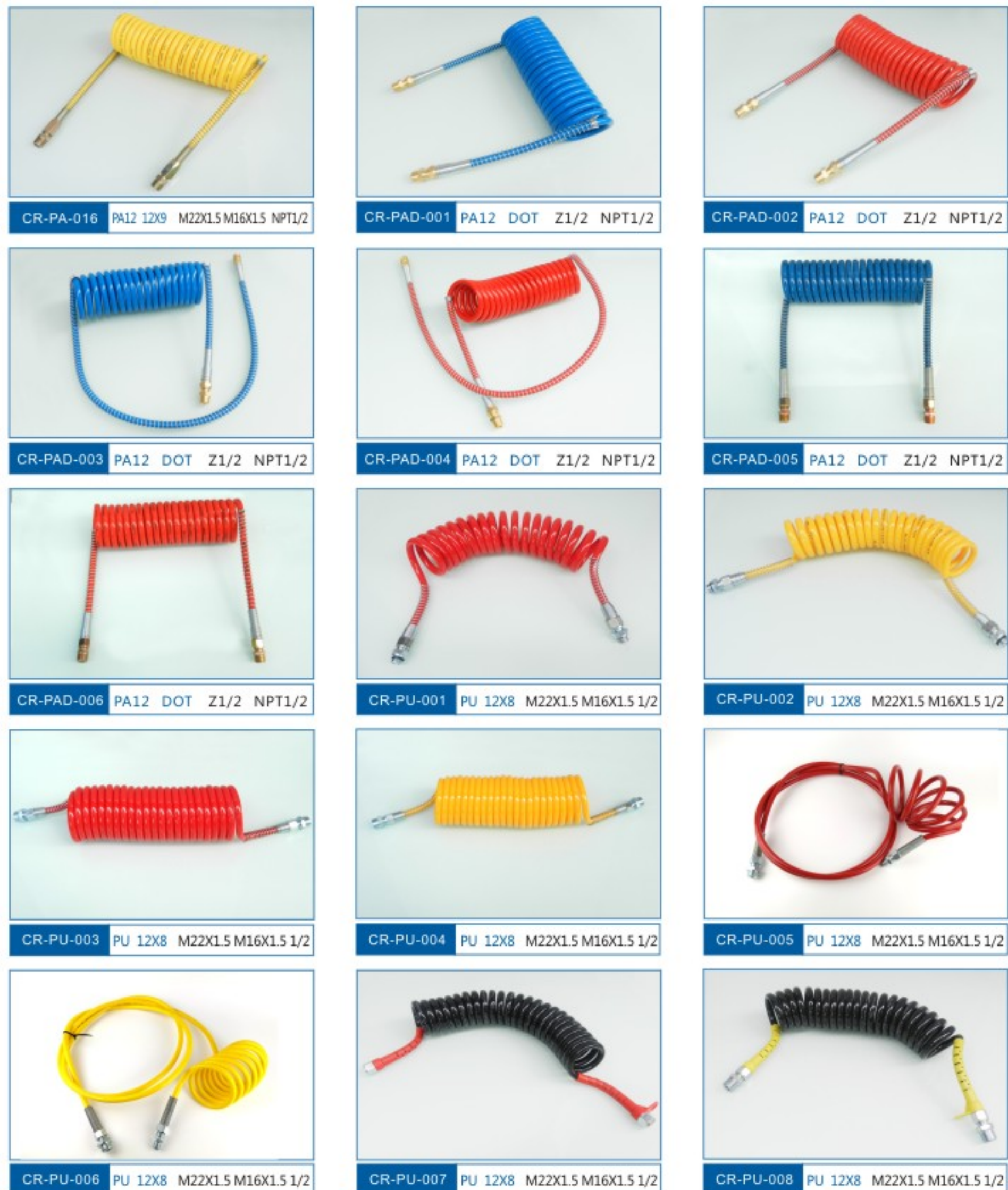

NOTE: Available Color: Black,Red,Yellow,Blue Material: PA11 PA12 PA6

双气层加螺旋管

Trailer Air Brake Reinforced Hose/Air Brake Coil With Double Layer



NOTE: Available Color: Black,Red,Yellow,Blue Material: PA11 PA12



挂车七芯线

Trailer Seven Core Cable/Electrical Cable/ABS/EBS Cable



CR-C-001 PA N&S 5M 6.5M 7M



CR-C-002 PA 5M 6.5M 7M



CR-C-003 PA N&S 5M 6.5M 7M



CR-C-004 PA 5M 6.5M 7M



CR-C-005 2PIN



CR-C-006 3PIN

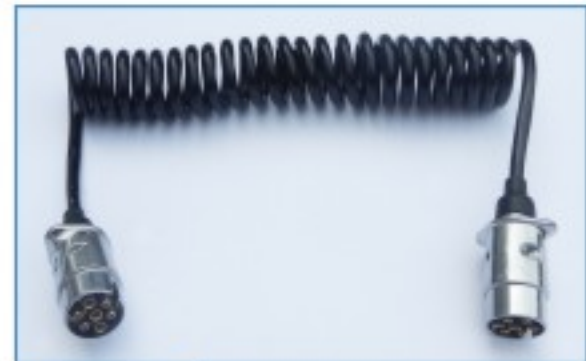

CR-C-007 PU N&S 3.5M 4M 4.5M 5M



CR-C-008 PU 3.5M 4M 4.5M 5M



CR-C-009 PU N&S 3.5M 4M 4.5M 5M



CR-C-010 PU 5PIN 7PIN



CR-C-011 PU N&S 3.5M 4M 4.5M 5M



CR-C-012 PU N&S 3.5M 4M 4.5M 5M



CR-C-013 PU N&S 3.5M 4M 4.5M 5M



CR-C-014 PU N&S 2M



CR-C-015 PU N&S 3.5M 4M 4.5M 5M

挂车七芯线

Trailer Seven Core Cable/Electrical Cable/ABS/EBS Cable



CR-C-016 PA PU 3.5M 4M 4.5M 5M



CR-C-017 PU 3.5M 4M 4.5M 5M



CR-C-018 Seven core cable



CR-C-019 PU 3.5M 4M 4.5M 5M



CR-C-020 PU 3.5M 4M 4.5M 5M



CR-C-021 PU 3.5M 4M 4.5M 5M



CR-C-022 3.5M 4M 4.5M 5M



CR-C-023 4M 4.5M 5M



CR-C-024 3.5M 4M 4.5M 5M



CR-C-025 3.5M 4M 4.5M 5M



CR-C-026 3.5M 4M 4.5M 5M



CR-C-027 24V Metal



CR-C-028 N&S 24V Metal



CR-C-029 24V Metal



CR-C-030 24V Metal



插头、插座  
Electrical Cable Plug & Socket



CR-C-031 12V Metal



CR-C-032 N&S 24V Plastic



CR-C-033 N&S 24V Plastic



CR-C-034 N&S 12V Plastic



CR-C-035 N&S 24V Plastic



CR-C-036 7PIN 5PIN



CR-C-037 15PIN



CR-C-038 7PIN 15PIN



CR-C-039 2x7PIN-15PIN



CR-C-040 NPT1/2



CR-C-041 M16x1.5 M22x1.5



CR-C-042 M16x1.5 M22x1.5 NPT1/2



CR-C-043 M22x1.5



CR-C-044 NPT1/2



CR-C-045 NPT3/8



CR-C-046 NPT1/2



CR-C-047 1/2 M16x1.5 M22x1.5



CR-C-048 1/2 M16x1.5 M22x1.5



CR-C-049 3/8 1/4



CR-C-050 3/4



CR-C-051 1"



CR-C-052 M22x1.5 1/2



CR-C-053 M22x1.5 1/2



CR-C-054 1/2 M22x1.5



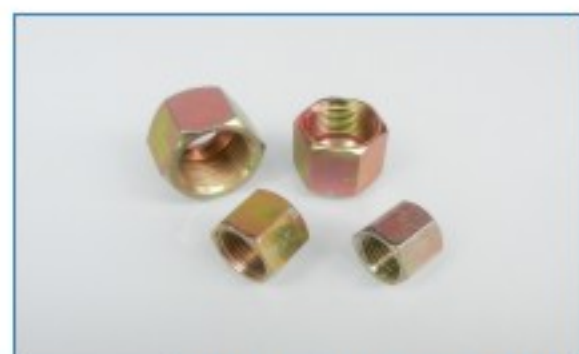

CR-001 M12x1.5 M14x1.5 M16x1.5 M18x1.5  
M22x1.5 M24x1.5 M26x1.5 M30x2



CR-002 M12x1.5 M14x1.5 M16x1.5 M18x1.5  
M22x1.5 M24x1.5 M26x1.5 M30x2



CR-003 1/2 7/8 3/4 3/8 7/16 1/4



CR-004 Ø4 Ø5 Ø6 Ø8 Ø10  
Ø12 Ø14 Ø15 Ø16 Ø18



CR-005 Ø4 Ø5 Ø6 Ø8 Ø10  
Ø12 Ø14 Ø15 Ø16 Ø18



CR-006 1/4 5/16 3/8 1/2 5/8 Ø4 Ø5  
Ø6 Ø8 Ø10 Ø12 Ø14 Ø16 Ø18



CR-007 M4 M6 M8 M10 M12  
M14 M15 M16 M18



CR-008 M4 M6 M8 M10 M12  
M14 M16 M18



CR-009 M4 M6 M8 M10 M12  
M14 M16 M18



CR-010 M8x1 M10x1 M12x1.5 M14x1.5 M16x1.5  
M18x1.5 M20x1.5 M22x1.5 M24x1.5 M30x2



CR-011 M22x1.5-M12x1.5 M22x1.5-M14x1.5  
M22x1.5-M16x1.5 M22x1.5-M18x1.5



CR-012 M22x1.5-M16x1.5 M22x1.5-M18x1.5  
M22x1.5-1/2 M22x1.5-3/8



CR-013 M12x1.5 M14x1.5 M16x1.5  
M18x1.5 M22x1.5



CR-014 M22x1.5-M12x1.5 M22x1.5-M14x1.5  
M22x1.5-M16x1.5 M22x1.5-M18x1.5

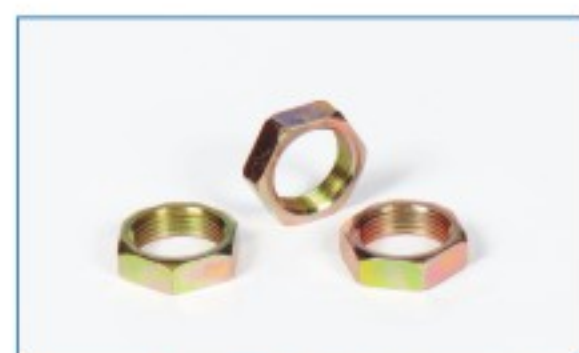

CR-015 M12x1.5 M14x1.5 M16x1.5  
M18x1.5 M22x1.5



CR-016 M12x1.5 M14x1.5 M16x1.5  
M18x1.5 M22x1.5



CR-017



CR-018 3M12x1.5 3M14x1.5 3M16x1.5  
3M18x1.5 3M22x1.5



CR-019 3M22x1.5

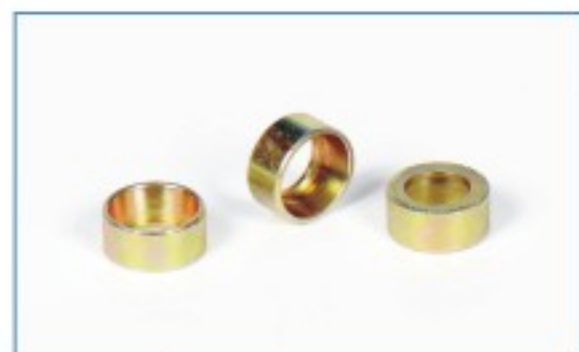

CR-020

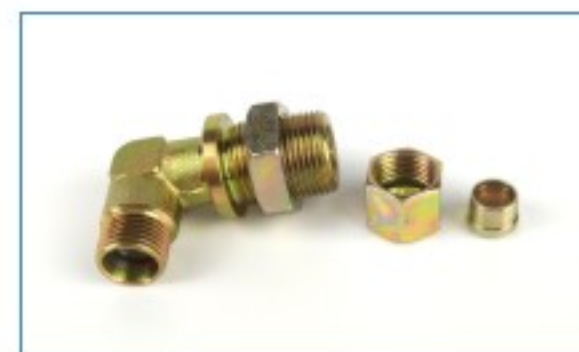

CR-021 M18x1.5-M22x1.5 M16x1.5-M22x1.5  
M22x1.5-M22x1.5



CR-022 M14x1.5-3/8 M16x1.5-3/8  
M18x1.5-3/8



CR-023 M22x1.5-M18x1.5 1/2-M18x1.5  
M16x1.5-M18x1.5

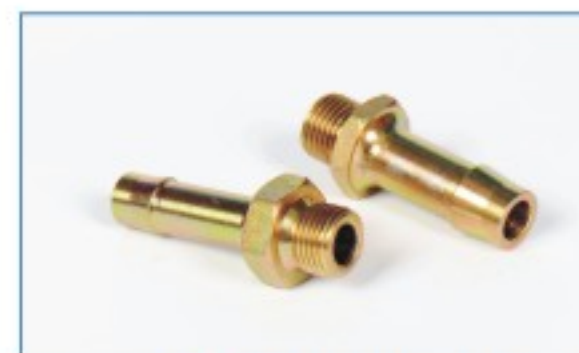

CR-024 M22x1.5-Ø16 M16x1.5-Ø13  
M16x1.5-Ø11



CR-025



CR-026 M4 M6 M8 M10 M12 M14 M15  
M16 M18 1/4 3/8 1/2



CR-027 M4 M6 M8 M10 M12 M14 M15  
M16 M18 1/4 3/8 1/2



CR-028 M22x1.5-Ø6 M22x1.5-Ø8  
M22x1.5-Ø10 M22x1.5-Ø12



CR-029 M22x1.5-Ø6 M22x1.5-Ø8  
M22x1.5-Ø10 M22x1.5-Ø12



CR-030 M22x1.5-Ø6 M22x1.5-Ø8  
M22x1.5-Ø10 M22x1.5-Ø12





CR-031 M22x1.5-Ø6 M22x1.5-Ø8  
M22x1.5-Ø10 M22x1.5-Ø12



CR-032 M22x1.5-Ø6 M22x1.5-Ø8  
M22x1.5-Ø10 M22x1.5-Ø12



CR-033 M22x1.5-Ø6 M22x1.5-Ø8  
M22x1.5-Ø10 M22x1.5-Ø12



CR-034



CR-035



CR-036



CR-037



CR-038 10x6 10x8 12x6 12x8 12x10 14x6 14x8  
14x10 14x12 16x6 16x8 16x10 16x12



CR-039

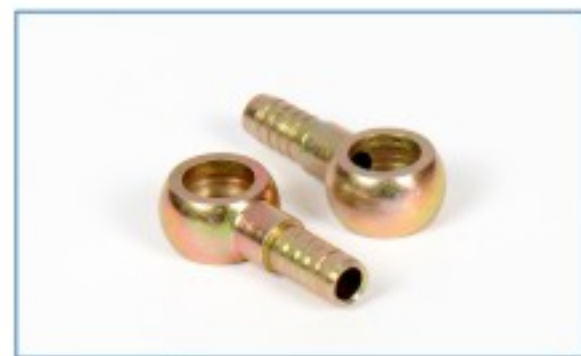

CR-040



CR-041



CR-042 M8x1 M10x1 M12x1.5 M14x1.5  
M16x1.5 M18x1.5 M20x1.5 M22x1.5



CR-043 M8x1 M10x1 M12x1.5 M14x1.5  
M16x1.5 M18x1.5 M20x1.5 M22x1.5



CR-044 M16 M22



CR-045 NPT 1/2



CR-046 M22x1.5-M22x1.5



CR-047 M16x1.5-M18x1.5



CR-048 M22x1.5-M12x1.5 M22x1.5-M14x1.5  
M22x1.5-M16x1.5 M22x1.5-M18x1.5



CR-049 ED seal INCH METRIC



CR-050 M22x1.5-M12x1.5 M22x1.5-M14x1.5  
M22x1.5-M16x1.5 M22x1.5-M18x1.5



CR-051 M2x1.5-M12x1.5 M2x1.5-M14x1.5  
M2x1.5-M16x1.5 M2x1.5-M18x1.5 M2x1.5-M22x1.5



CR-052 M22x1.5-Ø16 M16x1.5-Ø13



CR-053 M12x1.5 M14x1.5 M16x1.5  
M18x1.5 M22x1.5



CR-054 M12x1.5 M14x1.5 M16x1.5  
M18x1.5 M22x1.5



CR-055 M12x1.5 M14x1.5 M16x1.5  
M18x1.5 M22x1.5



CR-056 M12x1.5 M14x1.5 M16x1.5  
M18x1.5 M22x1.5



CR-057 M12x1.5 M14x1.5 M16x1.5  
M18x1.5 M22x1.5



CR-058 M12x1.5 M14x1.5 M16x1.5  
M18x1.5 M22x1.5



CR-059 M12x1.5 M14x1.5 M16x1.5  
M18x1.5 M22x1.5



CR-060 M12x1.5 M14x1.5 M16x1.5  
M18x1.5 M22x1.5





CR-061 M12x1.5 M14x1.5 M16x1.5  
M18x1.5 M22x1.5



CR-062 M22x1.5-M22x1.5 M22x1.5-M18x1.5  
M22x1.5-M16x1.5



CR-063 M12x1.5 M14x1.5 M16x1.5  
M18x1.5



CR-064 3M22x1.5



CR-065 M12 M14 M16 M18 M22



CR-066



CR-067



CR-068 10mm 12mm 14mm 16mm  
18mm 20mm 22mm 24mm



CR-069 10mm 12mm 14mm 16mm  
18mm 20mm 22mm 24mm



CR-070 10mm 12mm 14mm 16mm  
18mm 20mm 22mm 24mm



CR-071 10mm 12mm 14mm 16mm  
18mm 20mm 22mm 24mm



CR-072 10mm 12mm 14mm 16mm  
18mm 20mm 22mm 24mm



CR-073 Steel grease nipple

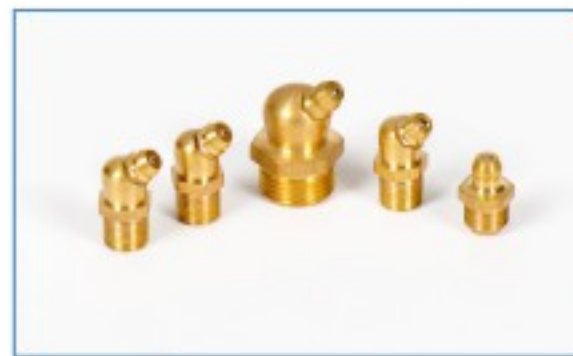

CR-074 Brass grease nipple



CR-075 Stainless steel grease nipple



CR-076



CR-077



CR-078



CR-079 00110 00210 03310 00400



CR-080



CR-081



CR-082



CR-083



CR-084

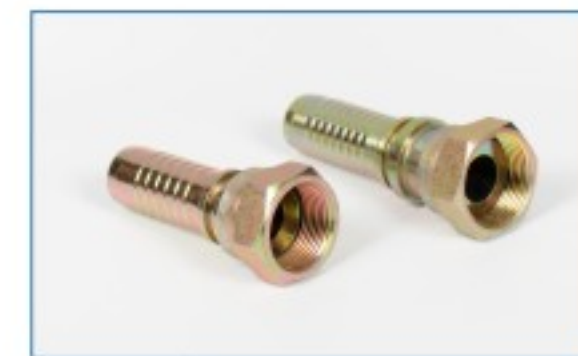

CR-085



CR-086



CR-087

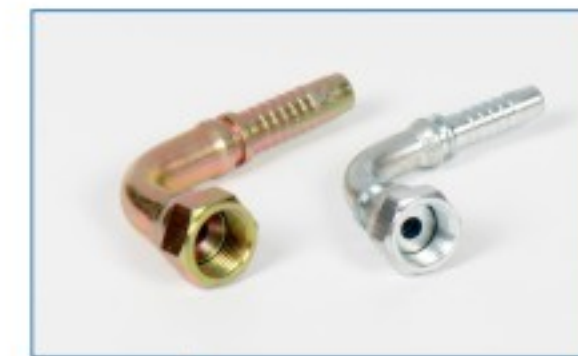

CR-088

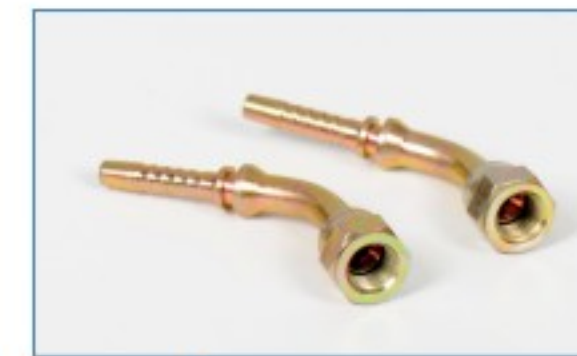

CR-089

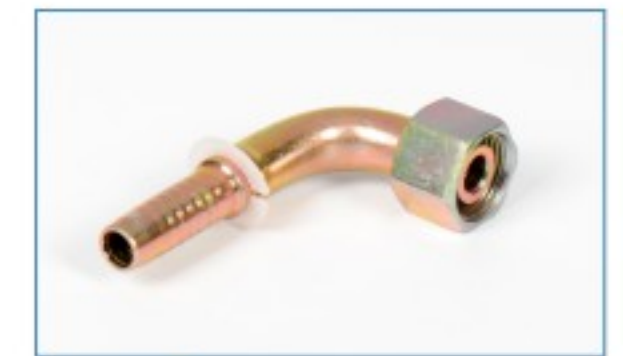

CR-090





CR-091 1/4 3/8 1/2 3/4 1"



CR-092 1/4 3/8 1/2 3/4 1"



CR-093 1/4 3/8 1/2 3/4 1"



CR-094



CR-095



CR-096



CR-097



CR-098



CR-099 Ø4 Ø5 Ø6 Ø7 Ø8 Ø9 Ø10 Ø11 Ø12  
Ø13 Ø14 Ø15 Ø16 1/4 3/8 1/2



CR-100 Ø4 Ø5 Ø6 Ø8 Ø10 Ø12 Ø14 Ø15 Ø16  
1/4 3/8 1/2



CR-101 Ø4 Ø5 Ø6 Ø8 Ø10 Ø12 Ø14 Ø15 Ø16  
1/4 3/8 1/2



CR-102 Ø4 Ø6 Ø8 Ø10 Ø12



CR-103 Ø4 Ø6 Ø8 Ø10 Ø12



CR-104 1/8 Ø6 Ø8 Ø10 Ø12  
1/4 3/8 1/2 Ø6 Ø8 Ø10 Ø12

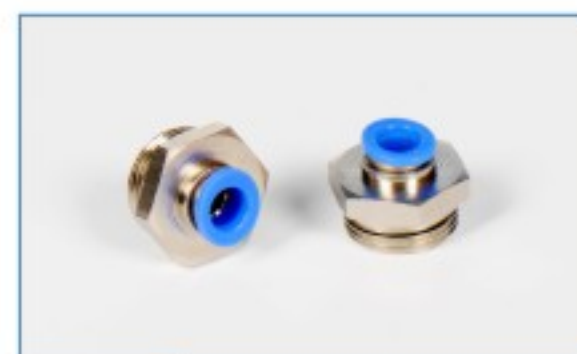

CR-105 M12x1.5 M14x1.5 M16x1.5 M18x1.5 M22x1.5  
Ø6 Ø8 Ø10 Ø12 Ø15



CR-106 1/8 1/4 3/8 1/2  
Ø4 Ø6 Ø8 Ø10 Ø12



CR-107 1/8 1/4 3/8 1/2  
Ø6 Ø8 Ø10 Ø12



CR-108 Ø6x4 Ø8x6



CR-109



CR-110 HVFF Ø6 Ø8 Ø10 Ø12



CR-111 Ø4 Ø5 Ø6 Ø8 Ø10 Ø12 Ø14 Ø16  
1/4 3/8 1/2



CR-112 Ø4 Ø5 Ø6 Ø8 Ø10 Ø12 Ø14 Ø16  
1/4 3/8 1/2



CR-113 Ø4 Ø5 Ø6 Ø8 Ø10 Ø12 Ø14 Ø16  
1/4 3/8 1/2



CR-114 Ø4 Ø6 Ø8 Ø10 Ø12



CR-115 Ø4 Ø6 Ø8 Ø10 Ø12

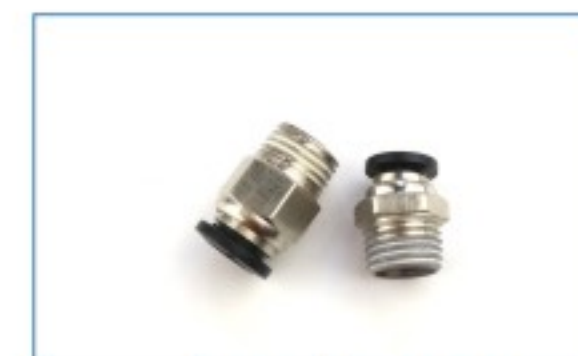

CR-116 1/8 Ø6 Ø8 Ø10 Ø12  
1/4 3/8 1/2 Ø6 Ø8 Ø10 Ø12



CR-117 1/8 1/4 3/8 1/2  
Ø4 Ø6 Ø8 Ø10 Ø12



CR-118 1/8 1/4 3/8 1/2  
Ø6 Ø8 Ø10 Ø12



CR-119 Ø4 Ø6 Ø8 Ø10 Ø12 Ø14 Ø16



CR-120 Ø4 Ø6 Ø8 Ø10 Ø12 Ø14 Ø16





CR-121    Ø4 Ø6 Ø8 Ø10 Ø12 Ø14 Ø16



CR-122    Ø4 Ø6 Ø8 Ø10 Ø12 Ø14 Ø16  
1/4 3/8 1/2



CR-123    Ø4 Ø6 Ø8 Ø10 Ø12 Ø14 Ø16  
1/4 3/8 1/2



CR-124    Ø4 Ø6 Ø8 Ø10 Ø12 Ø14 Ø16  
1/4 3/8 1/2



CR-125    Ø4 Ø5 Ø6 Ø8 Ø9 Ø10 Ø12 Ø14  
Ø15 Ø16 Ø18 1/4" 3/8" 1/2" 5/8"



CR-126    Ø4 Ø5 Ø6 Ø8 Ø9 Ø10 Ø12 Ø14  
Ø15 Ø16 Ø18 1/4 3/8 1/2 5/8



CR-127    Ø4 Ø5 Ø6 Ø8 Ø9 Ø10 Ø12 Ø14  
Ø15 Ø16 Ø18 1/4 3/8 1/2 5/8



CR-128    Ø4 Ø5 Ø6 Ø8 Ø9 Ø10 Ø12 Ø14  
Ø15 Ø16 Ø18 1/4 3/8 1/2 5/8



CR-129    M12x1.5 M14x1.5 M16x1.5 M18x1.5 M22x1.5  
Ø6 Ø8 Ø10 Ø12 Ø15



CR-130    1/4 1/8    Ø6 Ø8 Ø10 Ø12  
3/8 1/2    Ø6 Ø8 Ø10 Ø12



CR-131    M12x1.5 M14x1.5 M16x1.5 M18x1.5 M22x1.5  
Ø6 Ø8 Ø10 Ø12 Ø15



CR-132    1/4 1/8    Ø6 Ø8 Ø10 Ø12  
3/8 1/2    Ø6 Ø8 Ø10 Ø12



CR-133    1/8 1/4    Ø6 Ø8 Ø10 Ø12  
3/8 1/2    Ø6 Ø8 Ø10 Ø12



CR-134    1/8 3/8    Ø6 Ø8 Ø10 Ø12  
1/4 1/2    Ø6 Ø8 Ø10 Ø12



CR-135    1/8 3/8    Ø6 Ø8 Ø10 Ø12  
1/4 1/2    Ø6 Ø8 Ø10 Ø12



CR-136    Ø6 Ø8 Ø10 Ø12 Ø14 Ø16



CR-137    1/8 1/4    Ø4 Ø6 Ø8 Ø10 Ø12  
3/8 1/2    Ø6 Ø8 Ø10 Ø12



CR-138    1/8    Ø6 Ø8 Ø10  
1/4 3/8 1/2    Ø6 Ø8 Ø10 Ø12



CR-139    Ø6 Ø8 Ø10 Ø12



CR-140    Ø4 Ø6 Ø8 Ø10 Ø12



CR-141    Ø6 Ø8 Ø10 Ø12



CR-142    Ø6 Ø8 Ø10 Ø12 Ø14 Ø16



CR-143    Ø6 Ø8 Ø10 Ø12 Ø14  
1/4 3/8 1/2



CR-144    Ø6 Ø8 Ø10 Ø12 Ø14  
1/4 3/8 1/2



CR-145    Ø6 Ø8 Ø10 Ø12 Ø14



CR-146    Ø6 Ø8 Ø10 Ø12 Ø14



CR-147    1/8 1/4    Ø4 Ø6 Ø8 Ø10 Ø12  
3/8 1/2    Ø6 Ø8 Ø10 Ø12 Ø14 Ø16



CR-148    1/8 1/4 3/8    Ø6 Ø8 Ø10 Ø12  
1/2    Ø6 Ø8 Ø10 Ø12 Ø14



CR-149    1/8 1/4 3/8 1/2  
Ø6 Ø8 Ø10 Ø12 Ø14 Ø16



CR-150





CR-151



CR-152



CR-153 M16x1.5 T6/T8



CR-154 160mm 120mm



CR-155 95mm 140mm



CR-156 1/2



CR-157 M22



CR-158 M22



CR-159 3/8



CR-160 1/4 3/8



CR-161 1/4



CR-162 M16 M22



CR-163 F12 F16 F22



CR-164 Ø6 Ø8 Ø10 Ø12 Ø14



CR-165



CR-166



CR-167



CR-168



CR-169



CR-170



CR-171



CR-172



CR-173



CR-174



CR-175



CR-176



CR-177



CR-178



CR-179



CR-180





CR-181



CR-182 1/4" 1/8" M10x1 M12x1.5 M14x1.5 M16x1.5 M18x1.5 M22x1.5 M26x1.5



CR-183



CR-184



CR-185 1/4" 1/8" M10x1 M12x1.5 M14x1.5 M16x1.5 M18x1.5 M22x1.5 M26x1.5



CR-186



CR-187



CR-188 NG6 NG8 NG12  
6/8/10/12/14/16



CR-189 NG6 NG8 NG12  
6/8/10/12/14/16



CR-190 NG6 NG8 NG12  
6/8/10/12/14/16



CR-191 Ng6 NG8 NG12  
6/8/10/12/14/16



CR-192 NG6 NG8 NG12  
6/8/10/12/14/16



CR-193 Ng6 NG8 NG12



CR-194 M10P5 M12P5 M14P5  
M16P5 M22P5



CR-195 M10P5 M12P5 M14P5  
M16P5 M22P5



CR-196 F10 F12 F14 F16 F18 F22



CR-197 M10 M12 M16 M22



CR-198 M16F12 M22F12 M22F16



CR-199 M22F16 M28F16



CR-200 M12 M16 M22 M22M16



CR-201 M16M22F16 M22M22F16



CR-202 M10F12 M12F16 M14F16  
M16F22 M12F22



CR-203 M12 M16 M22  
Ø10 Ø11 Ø13 Ø14.5



CR-204 F10 F12



CR-205 Ø6 Ø8 Ø9 Ø10 Ø11  
Ø12 Ø14 Ø15 Ø16 Ø18



CR-206 F10 F12 F16 F22



CR-207 M10 M12 M16 M22  
Ø6 Ø8 Ø10 Ø12 Ø15 Ø16



CR-208



CR-209 M10F12 M12F12 M12F16  
M16F16 M22F16 M22F22



CR-210 M16F16





CR-211 F16-P5



CR-212 F12 F16 F22



CR-213 06P5 08P5 10P5 12P5



CR-214 F12 F16 F22



CR-215 M16P5



CR-216 M16F16



CR-217 M10F12 M12F12 M16F12 M16F16 M22F16 M22F22



CR-218 M10F12 M12F12 M16F12 M16F16 M22F16 M22F22



CR-219 M16x1.5-P5



CR-220 F10 F12 F16 F22  
06 08 010 012 015 016



CR-221 M10 M12 M16 M22  
06 08 010 012 015 016



CR-222



CR-223 M12 M14 M16 M22  
06 08 010 012 015 016



CR-224 F12 F14 F16 F22  
06 08 010 012 015 016



CR-225 M12 M16 M22  
06 08 010 012 015 016



CR-226 06 08 010 012 015 016



CR-227 M12 M16 M22  
06 08 010 012 015 016



CR-228 06 08 010 012 015 016



CR-229

Part Ref	Thread Size	Tube Size(mm)
	1/4"	12 x 9
	M12 x 1.5	12 x 9
	M14 x 1.5	12 x 9
	M16 x 1.5	12 x 9
	M18 x 1.5	12 x 9
	M16 x 1.5	15 x 12
	M22 x 1.5	15 x 12
	M16 x 1.5	16 x 12
	M22 x 1.5	16 x 12
	M16 x 1.5	18 x 14
	M22 x 1.5	18 x 14
	M26 x 1.5	18 x 14
	M12 x 1.5	9 x 6
	M16 x 1.5	9 x 6
	M22 x 1.5	9 x 6
	M12 x 1.5	11 x 8
	M16 x 1.5	11 x 8
	M22 x 1.5	11 x 8

Part Ref	Thread Size	Tube Size(mm)
	M10 x 1	4 x 2
	1/8"	6 x 4
	1/4	6 x 4
	M10 x 1	6 x 4
	M12 x 1.5	6 x 4
	M14 x 1.5	6 x 4
	M16 x 1.5	6 x 4
	M22 x 1.5	6 x 4
	1/8"	8 x 6
	1/4"	8 x 6
	M10 x 1	8 x 6
	M12 x 1.5	8 x 6
	M14 x 1.5	8 x 6
	M16 x 1.5	8 x 6
	M22 x 1.5	8 x 6
	1/4	10 x 7.5
	M10 x 1	10 x 7.5
	M12 x 1.5	10 x 7.5
	M12 x 1.5	10 x 7
	M14 x 1.5	10 x 7.5
	M16 x 1.5	10 x 7.5
	M16 x 1.5	10 x 7
	M18 x 1.5	10 x 7.5
	M18 x 1.5	10 x 7
	M22 x 1.5	10 x 7.5
	M22 x 1.5	10 x 7



CR-230

6-M10*1	8-M16*1.5	12-M12*1.5
6-M12*1.5	8-M22*1.5	12-M14*1.5
6-M14*1.5	10-M12*1.5	12-M16*1.5
6-M16*1.5	10-M14*1.5	12-M18*1.5
8-M10*1	10-M16*1.5	12-M22*1.5
8-M12*1.5	10-M18*1.5	15-M16*1.5
8-M14*1.5	10-M22*1.5	15-M22*1.5





CR-231 M4 M6 M8 M10 M12 M14 M16 M18  
1/4 3/8 1/2 5/8



CR-232 M4 M6 M8 M10 M12 M14 M16 M18  
1/4 3/8 1/2 5/8



CR-233 M4 M6 M8 M10 M12 M14 M16 M18  
1/4 3/8 1/2 5/8

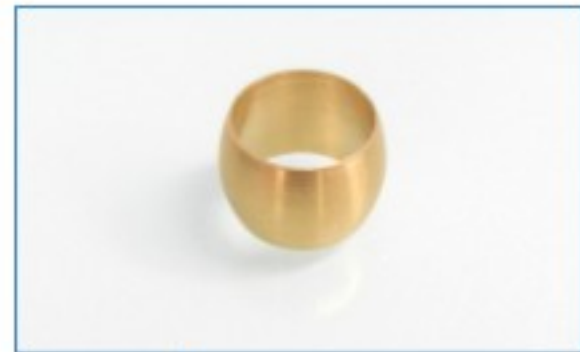

CR-234 1/4 5/16 3/8 1/2 5/8 3/4



CR-235 1/4 5/16 3/8 1/2 5/8 3/4



CR-236 NPT1/4 NPT3/8 NPT1/2



CR-237 3/8-1/4



CR-238 1/4 5/16 3/8 1/2 5/8 3/4



CR-239 1/4 5/16 3/8 1/2 5/8 3/4



CR-240 1/4 5/16 3/8 1/2 5/8 3/4



CR-241 1/8 1/4 5/16 3/8 1/2 3/4 5/8  
Ø1/4 Ø5/16 Ø3/8 Ø1/2



CR-242 1/8 1/4 5/16 3/8 1/2 3/4 5/8  
Ø1/4 Ø5/16 Ø3/8 Ø1/2

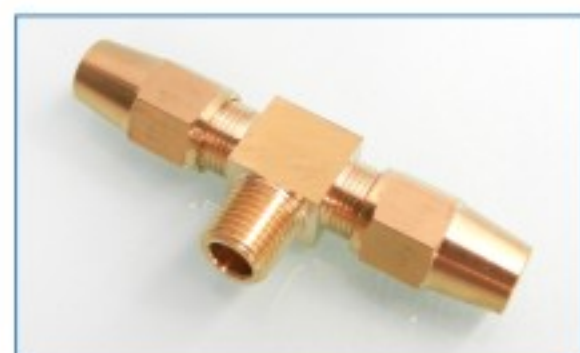

CR-243 1/8 1/4 5/16 3/8 1/2 3/4 5/8  
Ø1/4 Ø5/16 Ø3/8 Ø1/2



CR-244 Ø6 Ø8 Ø10 Ø12 Ø16 Ø18



CR-245 Ø6 Ø8 Ø10 Ø12 Ø16 Ø18



CR-246 M22x1.5-12 M16x1.5-12  
M22x1.5-10 M16x1.5-10



CR-247



CR-248



CR-249



CR-250



CR-251



CR-252



CR-253



CR-254



CR-255



CR-256

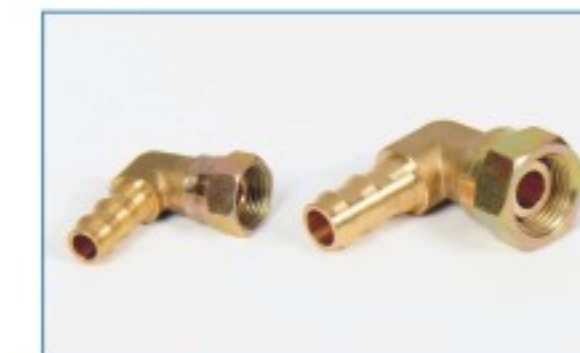

CR-257



CR-258



CR-259



CR-260





CR-261



CR-262



CR-263

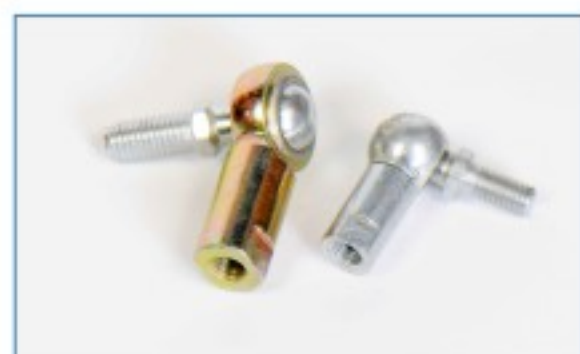

CR-264

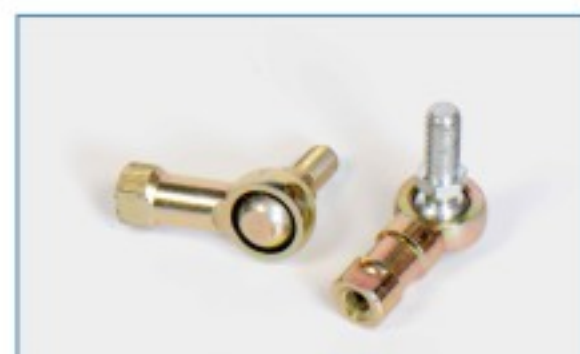

CR-265



CR-266



CR-267



CR-268

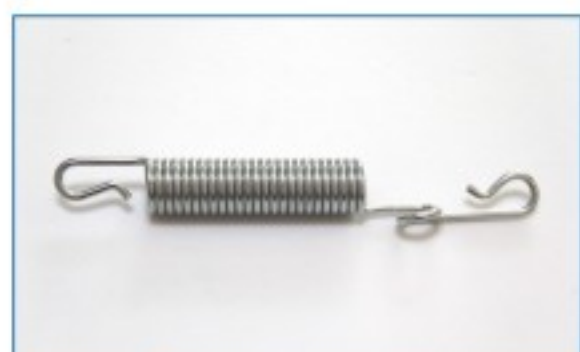

CR-269



CR-270



CR-271



CR-272



CR-273



CR-274



CR-275



CR-276



CR-277



CR-278

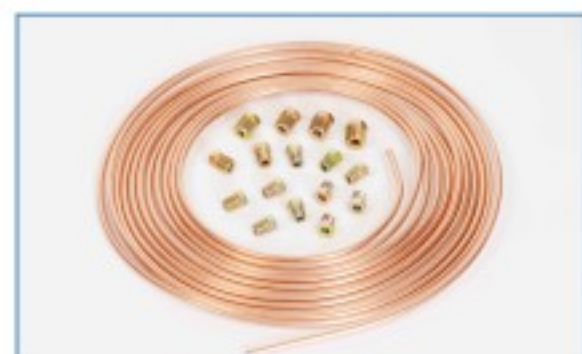

CR-279



CR-280



CR-281



CR-282



CR-283



CR-284



CR-285



CR-286

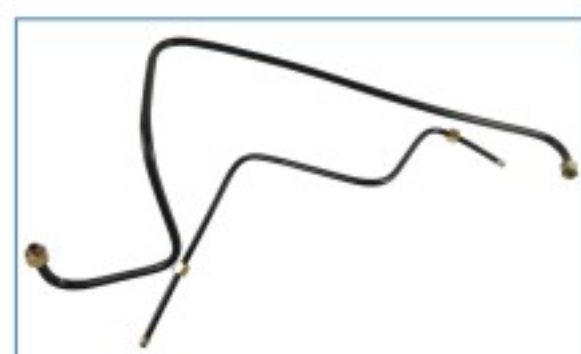

CR-287



CR-288



CR-289



CR-290



**DOT插入式系列 DOT Push-In Fittings**

DOT-UC 等径直通  
**CR-291**

Union

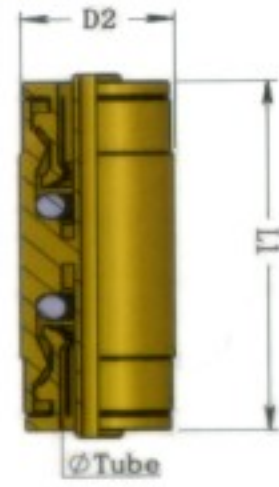

PART NO.	Tube		
	O.D.*I.D.	D2	L1
DOT-UC-04	4*2.5	8.8	30
DOT-UC-06	6*4	11.7	34
DOT-UC-08	8*6	13.7	38
DOT-UC-10	10*8	16.3	42.5
DOT-UC-12	12*10	18.3	44.5
DOT-UC-IN02	6.35*4.3	11.7	34
DOT-UC-IN03	9.52*6.38	16.3	42.5
DOT-UC-IN04	12.7*9.55	18.3	44.5

DOT-HUL 等径直角  
**CR-292**

Union Elbow

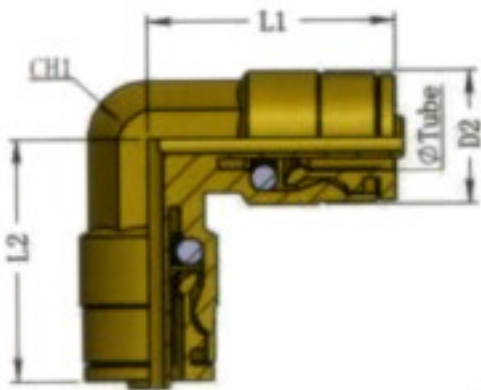

PART NO.	Tube					
	O.D.*I.D.	D2	L1	L2	CH	
DOT-HUL-06	6*4	12.7	22	22	9.5	
DOT-HUL-08	8*6	15.5	25	25	12	
DOT-HUL-10	10*8	17.5	28	28	12.7	
DOT-HUL-12	12*10	19.5	31	31	16	
DOT-HUL-IN02	6.35*4.3	12.7	22	22	9.5	
DOT-HUL-IN03	9.52*6.38	17.5	28	28	12.7	
DOT-HUL-IN04	12.7*9.55	19.5	31	31	16	

DOT-HUC 等径三通  
**CR-293**

Union Tee

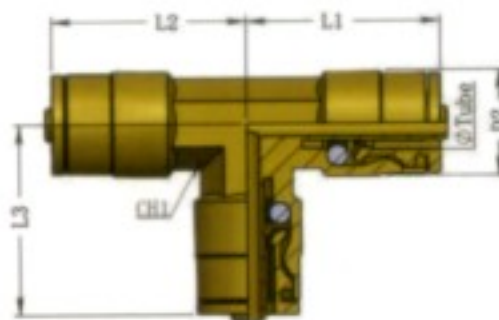

PART NO.	Tube						
	O.D.*I.D.	D2	L1	L2	L3	CH	
DOT-HUT-06	6*4	12.7	22	22	22	9.5	
DOT-HUT-08	8*6	15.5	25	25	25	12	
DOT-HUT-10	10*8	17.5	28	28	28	12.7	
DOT-HUT-12	12*10	19.5	31	31	31	16	
DOT-HUT-IN02	6.35*4.3	12.7	22	22	22	9.5	
DOT-HUT-IN03	9.52*6.38	17.5	28	28	28	12.7	
DOT-HUT-IN04	12.7*9.55	19.5	31	31	31	16	

DOT-C 直通, 外螺纹 Taper Stud, Male  
**CR-294**

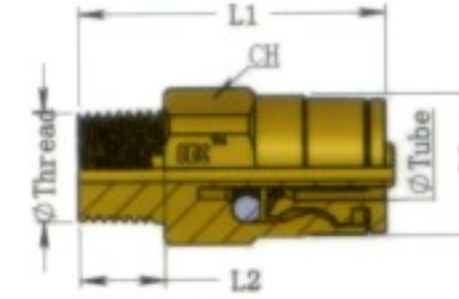

PART NO.	Thread	Tube		D2	L1	L2	CH
		O.D.*I.D.					
DOT-C-06-R01	R1/8	6*4		11.7	20.5	7.5	12
DOT-C-06-R02	R1/4	6*4		11.7	21	11	14
DOT-C-08-R01	R1/8	8*6		13.7	24.5	7.5	14
DOT-C-08-R02	R1/4	8*6		13.7	23	11	14
DOT-C-08-R03	R3/8	8*6		13.7	22	11.5	17
DOT-C-10-R02	R1/4	10*8		16.3	28.5	11	17
DOT-C-10-R03	R3/8	10*8		16.3	25.5	11.5	17
DOT-C-10-R04	R1/2	10*8		16.3	26.5	14	22
DOT-C-12-R02	R1/4	12*10		18.3	27	11	19
DOT-C-12-R03	R3/8	12*10		18.3	31.5	11.5	19
DOT-C-12-R04	R1/2	12*10		18.3	27	14	22
DOT-C-IN02-N01	NPT1/8	6.35*4.3		11.7	23.5	8	12
DOT-C-IN02-N02	NPT1/4	6.35*4.3		11.7	26.5	12	14
DOT-C-IN02-N03	NPT3/8	6.35*4.3		11.7	27	12	19
DOT-C-IN03-N01	NPT1/8	9.52*6.38		16.3	30	8	17
DOT-C-IN03-N02	NPT1/4	9.52*6.38		16.3	34	12	17
DOT-C-IN03-N03	NPT3/8	9.52*6.38		16.3	29	12	19
DOT-C-IN04-N02	NPT1/4	12.7*9.55		18.3	33	12	19
DOT-C-IN04-N03	NPT3/8	12.7*9.55		18.3	31.5	12	19
DOT-C-IN04-N04	NPT1/2	12.7*9.55		18.3	30	15.5	22

DOT-CF 直通, 内螺纹 Female Stud  
**CR-295**

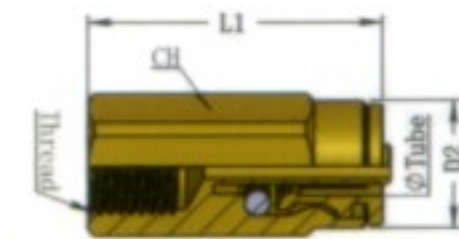

PART NO.	Thread	Tube		D2	L1	CH
		O.D.*I.D.				
DOT-CF-06-R01	R1/8	6*4		11.7	25	14
DOT-CF-06-R02	R1/4	6*4		11.7	29	17
DOT-CF-08-R01	R1/8	8*6		13.7	26	14
DOT-CF-08-R02	R1/4	8*6		13.7	29.5	17
DOT-CF-10-R02	R1/4	10*8		16.3	31.5	17
DOT-CF-10-R03	R3/8	10*8		16.3	33	22
DOT-CF-12-R02	R1/4	12*10		18.3	35	19
DOT-CF-12-R03	R3/8	12*10		18.3	35	22
DOT-CF-12-R04	R1/2	12*10		18.3	37	27
DOT-CF-IN02-N01	NPT1/8	6.35*4.3		11.7	25	14
DOT-CF-IN02-N02	NPT1/4	6.35*4.3		11.7	29	17
DOT-CF-IN03-N02	NPT1/4	9.52*6.38		16.3	31.5	17
DOT-CF-IN03-N03	NPT3/8	9.52*6.38		16.3	33	22
DOT-CF-IN04-N02	NPT1/4	12.7*9.55		18.3	35	19
DOT-CF-IN04-N03	NPT3/8	12.7*9.55		18.3	35	22
DOT-CF-IN04-N04	NPT1/2	12.7*9.55		18.3	37	27



DOT-HD 侧三通, 外螺纹 Lateral Tee, Male

CR-296

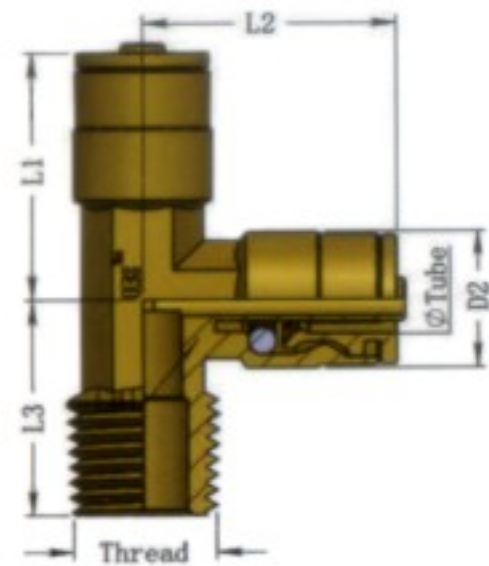

PART NO.	Thread	Tube O.D.*I.D.	D2	L1	L2	L3	CH
DOT-HD-06-R01	R1/8	6*4	12.7	22	22	20	9.5
DOT-HD-06-R02	R1/4	6*4	12.7	22	22	23	9.5
DOT-HD-08-R01	R1/8	8*6	15	25	25	23	12
DOT-HD-08-R02	R1/4	8*6	15	25	25	24	12
DOT-HD-08-R03	R3/8	8*6	15	27	27	26	12
DOT-HD-10-R02	R1/4	10*8	17.5	28	28	25	12.7
DOT-HD-10-R03	R3/8	10*8	17.5	28	28	25	12.7
DOT-HD-10-R04	R1/2	10*8	17.5	31	31	31	16
DOT-HD-12-R02	R1/4	12*10	19.5	31	31	26	16
DOT-HD-12-R03	R3/8	12*10	19.5	31	31	26	16
DOT-HD-12-R04	R1/2	12*10	19.5	31	31	31	16
DOT-HD-IN02-N01	NPT1/8	6.35*4.3	12.7	22	22	23	9.5
DOT-HD-IN02-N02	NPT1/4	6.35*4.3	12.7	22	22	23	9.5
DOT-HD-IN03-N02	NPT1/4	9.52*6.38	17.5	25	25	25	12.7
DOT-HD-IN03-N03	NPT3/8	9.52*6.38	17.5	27	27	25	12.7
DOT-HD-IN04-N02	NPT1/4	12.7*9.55	19.5	31	31	27	16
DOT-HD-IN04-N03	NPT3/8	12.7*9.55	19.5	31	31	27	16
DOT-HD-IN04-N04	NPT1/2	12.7*9.55	19.5	31	31	31	16

DOT-HLS 直角, 旋转外螺纹 Swiveling Elbow, Male

CR-297

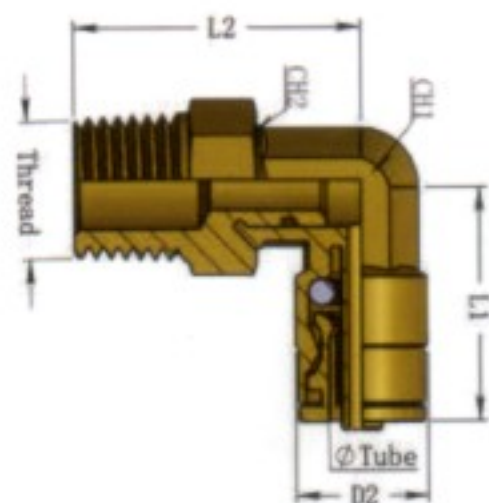

PART NO.	Thread	Tube O.D.*I.D.	D2	L1	L2	L3	CH
DOT-HLS-06-R01	R1/8	6*4	12.7	22	22	20	9.5
DOT-HLS-06-R02	R1/4	6*4	12.7	22	22	23	9.5
DOT-HLS-08-R01	R1/8	8*6	15	25	25	23	12
DOT-HLS-08-R02	R1/4	8*6	15	25	25	24	12
DOT-HLS-08-R03	R3/8	8*6	15	27	27	26	12
DOT-HLS-10-R02	R1/4	10*8	17.5	28	28	25	12.7
DOT-HLS-10-R03	R3/8	10*8	17.5	28	28	25	12.7
DOT-HLS-10-R04	R1/2	10*8	17.5	31	31	31	16
DOT-HLS-12-R02	R1/4	12*10	19.5	31	31	26	16
DOT-HLS-12-R03	R3/8	12*10	19.5	31	31	26	16
DOT-HLS-12-R04	R1/2	12*10	19.5	31	31	31	16
DOT-HLS-IN02-N01	NPT1/8	6.35*4.3	12.7	22	22	23	9.5
DOT-HLS-IN02-N02	NPT1/4	6.35*4.3	12.7	22	22	23	9.5
DOT-HLS-IN03-N02	NPT1/4	9.52*6.38	17.5	25	25	25	12.7
DOT-HLS-IN03-N03	NPT3/8	9.52*6.38	17.5	27	27	25	12.7
DOT-HLS-IN04-N02	NPT1/4	12.7*9.55	19.5	31	31	27	16
DOT-HLS-IN04-N03	NPT3/8	12.7*9.55	19.5	31	31	27	16
DOT-HLS-IN04-N04	NPT1/2	12.7*9.55	19.5	31	31	31	16

DOT-HL 直通, 外螺纹 Elbow, Male

CR-298

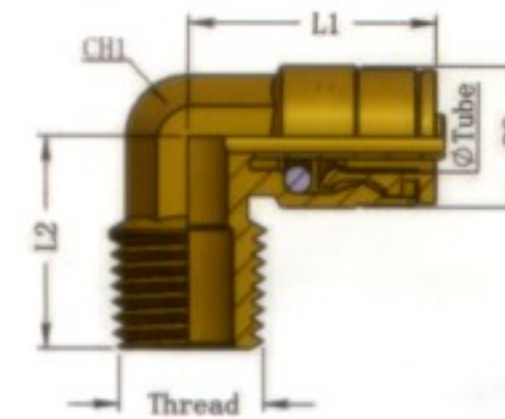

PART NO.	Thread	Tube O.D.*I.D.	D2	L1	L2	CH
DOT-HL-06-R01	R1/8	6*4	12.7	22	20	9.5
DOT-HL-06-R02	R1/4	6*4	12.7	22	23	9.5
DOT-HL-08-R01	R1/8	8*6	15	25	23	12
DOT-HL-08-R02	R1/4	8*6	15	25	24	12
DOT-HL-08-R03	R3/8	8*6	15	27	26	12
DOT-HL-10-R02	R1/4	10*8	17.5	28	25	12.7
DOT-HL-10-R03	R3/8	10*8	17.5	28	25	12.7
DOT-HL-10-R04	R1/2	10*8	17.5	31	31	16
DOT-HL-12-R02	R1/4	12*10	19.5	31	26	16
DOT-HL-12-R03	R3/8	12*10	19.5	31	26	16
DOT-HL-12-R04	R1/2	12*10	19.5	31	31	16
DOT-HL-IN02-N01	NPT1/8	6.35*4.3	12.7	22	23	9.5
DOT-HL-IN02-N02	NPT1/4	6.35*4.3	12.7	22	23	9.5
DOT-HL-IN03-N02	NPT1/4	9.52*6.38	17.5	25	25	12.7
DOT-HL-IN03-N03	NPT3/8	9.52*6.38	17.5	27	25	12.7
DOT-HL-IN04-N02	NPT1/4	12.7*9.55	19.5	31	27	16
DOT-HL-IN04-N03	NPT3/8	12.7*9.55	19.5	31	27	16
DOT-HL-IN04-N04	NPT1/2	12.7*9.55	19.5	31	31	16

DOT-HT 正三通, 外螺纹 Tee, Male

CR-299

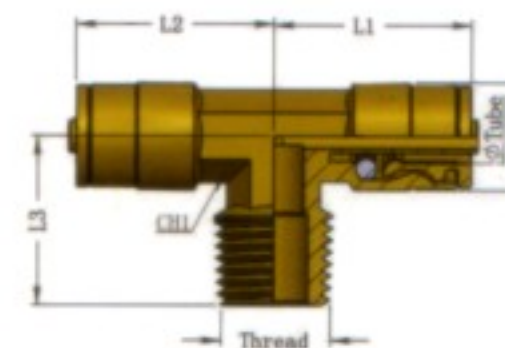

PART NO.	Thread	Tube O.D.*I.D.	D2	L1	L2	L3	CH
DOT-HT-06-R01	R1/8	6*4	12.7	22	22	20	9.5
DOT-HT-06-R02	R1/4	6*4	12.7	22	22	23	9.5
DOT-HT-08-R01	R1/8	8*6	15	25	25	23	12
DOT-HT-08-R02	R1/4	8*6	15	25	25	24	12
DOT-HT-08-R03	R3/8	8*6	15	27	27	26	12
DOT-HT-10-R02	R1/4	10*8	17.5	28	28	25	12.7
DOT-HT-10-R03	R3/8	10*8	17.5	28	28	25	12.7
DOT-HT-10-R04	R1/2	10*8	17.5	31	31	31	16
DOT-HT-12-R02	R1/4	12*10	19.5	31	31	26	16
DOT-HT-12-R03	R3/8	12*10	19.5	31	31	26	16
DOT-HT-12-R04	R1/2	12*10	19.5	31	31	31	16
DOT-HT-IN02-N01	NPT1/8	6.35*4.3	12.7	22	22	23	9.5
DOT-HT-IN02-N02	NPT1/4	6.35*4.3	12.7	22	22	23	9.5
DOT-HT-IN03-N02	NPT1/4	9.52*6.38	17.5	25	25	25	12.7
DOT-HT-IN03-N03	NPT3/8	9.52*6.38	17.5	27	27	25	12.7
DOT-HT-IN04-N02	NPT1/4	12.7*9.55	19.5	31	31	27	16
DOT-HT-IN04-N03	NPT3/8	12.7*9.55	19.5	31	31	27	16
DOT-HT-IN04-N04	NPT1/2	12.7*9.55	19.5	31	31	31	16



DOT-HTS 正三通, 旋转外螺纹 Swiveling Tee, Male

**CR-300**

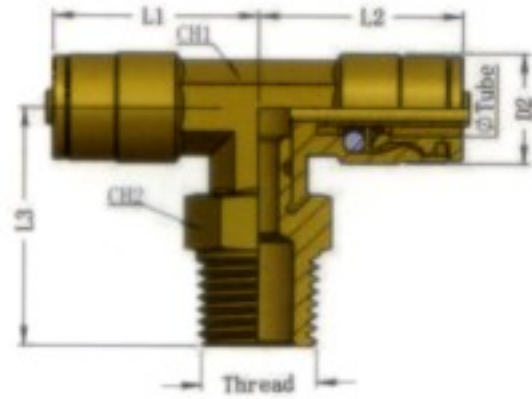

PART NO.	Thread	Tube O.D.*I.D.	D2	L1	L2	L3	CH
DOT-HTS-06-R01	R1/8	6*4	12.7	22	22	25	9.5
DOT-HTS-06-R02	R1/4	6*4	12.7	22	22	28	9.5
DOT-HTS-08-R01	R1/8	8*6	15	25	25	28	12
DOT-HTS-08-R02	R1/4	8*6	15	25	25	29	12
DOT-HTS-08-R03	R3/8	8*6	15	27	27	32	12
DOT-HTS-10-R02	R1/4	10*8	17.5	28	28	30	12.7
DOT-HTS-10-R03	R3/8	10*8	17.5	28	28	30	12.7
DOT-HTS-10-R04	R1/2	10*8	17.5	31	31	36	16
DOT-HTS-12-R02	R1/4	12*10	19.5	31	31	31	16
DOT-HTS-12-R03	R3/8	12*10	19.5	31	31	31	16
DOT-HTS-12-R04	R1/2	12*10	19.5	31	31	36	16
DOT-HTS-IN02-N01	NPT1/8	6.35*4.3	12.7	22	22	28	9.5
DOT-HTS-IN02-N02	NPT1/4	6.35*4.3	12.7	22	22	28	9.5
DOT-HTS-IN03-N02	NPT1/4	9.52*6.38	17.5	25	25	30	12.7
DOT-HTS-IN03-N03	NPT3/8	9.52*6.38	17.5	27	27	30	12.7
DOT-HTS-IN04-N02	NPT1/4	12.7*9.55	19.5	31	31	32	16
DOT-HTS-IN04-N03	NPT3/8	12.7*9.55	19.5	31	31	32	16
DOT-HTS-IN04-N04	NPT1/2	12.7*9.55	19.5	31	31	36	16

DOT-HDS 侧三通, 旋转外螺纹 Swiveling, Lateral Tee, Male

**CR-301**

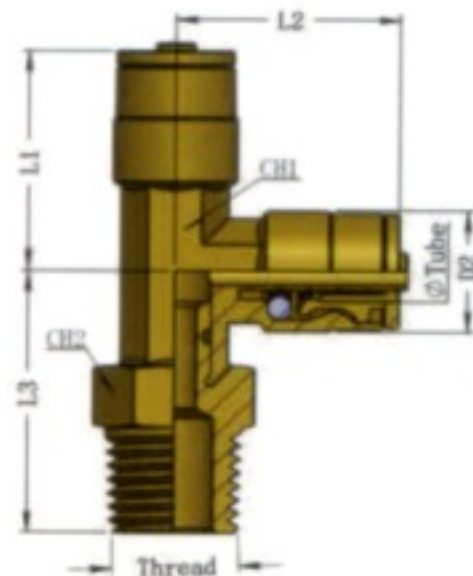

PART NO.	Thread	Tube O.D.*I.D.	D2	L1	L2	L3	CH
DOT-HDS-06-R01	R1/8	6*4	12.7	22	22	25	9.5
DOT-HDS-06-R02	R1/4	6*4	12.7	22	22	28	9.5
DOT-HDS-08-R01	R1/8	8*6	15	25	25	28	12
DOT-HDS-08-R02	R1/4	8*6	15	25	25	29	12
DOT-HDS-08-R03	R3/8	8*6	15	27	27	32	12
DOT-HDS-10-R02	R1/4	10*8	17.5	28	28	30	12.7
DOT-HDS-10-R03	R3/8	10*8	17.5	28	28	30	12.7
DOT-HDS-10-R04	R1/2	10*8	17.5	31	31	36	16
DOT-HDS-12-R02	R1/4	12*10	19.5	31	31	31	16
DOT-HDS-12-R03	R3/8	12*10	19.5	31	31	31	16
DOT-HDS-12-R04	R1/2	12*10	19.5	31	31	36	16
DOT-HDS-IN02-N01	NPT1/8	6.35*4.3	12.7	22	22	28	9.5
DOT-HDS-IN02-N02	NPT1/4	6.35*4.3	12.7	22	22	28	9.5
DOT-HDS-IN03-N02	NPT1/4	9.52*6.38	17.5	25	25	30	12.7
DOT-HDS-IN03-N03	NPT3/8	9.52*6.38	17.5	27	27	30	12.7
DOT-HDS-IN04-N02	NPT1/4	12.7*9.55	19.5	31	31	32	16
DOT-HDS-IN04-N03	NPT3/8	12.7*9.55	19.5	31	31	32	16
DOT-HDS-IN04-N04	NPT1/2	12.7*9.55	19.5	31	31	36	16

